

ACCESSIBLE CARTRIDGE

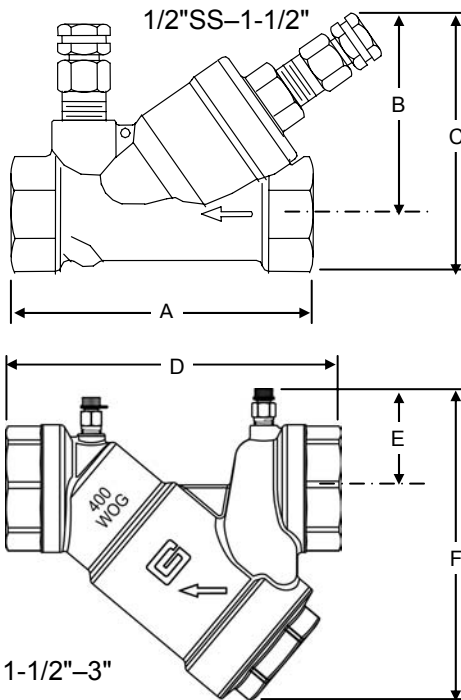

SPECIFICATIONS:

PSI / Temperature Rating: 230 PSI / 250° F
Cartridge: AISI Type 304 stainless steel
 AISI Type 17-7 PH stainless steel spring
Body Material: Forged brass (1/2" to 1-1/2")
 Cast brass (1-1/2"L to 3")
End Connections: Female NPT (Sweat Available on 1/2" to 3/4" Housing)
Seals: EPDM O-Rings
Body Tappings: 1/4" NPT with P/T test valves
Assembly: Valve comes fully assembled.

ACCESSORY OPTIONS:

Strainer¹: 20 mesh stainless steel

SIZE	MODEL NO.	HEAD LOSS IN FEET ²	PSID RANGE	GPM
1/2" SS	3K02B	7.4	2-32	.25, .33 .50, 1.00, 1.50, 2.00, 2.50, 3.00
1/2", 3/4", 1"	380	3.5	1-14	.33, .50, .67, 1.00, 1.33, 1.67, 2.00, 2.33, 2.67, 3.33, 4.00, 4.67, 5.00
		7.4	2-32	.55, .75, 1.00, 1.50, 2.00, 2.50, 3.00, 3.50, 4.00, 5.00, 6.00, 7.00, 8.00
		13.4	4-57	.75, 1.00, 1.33, 2.00, 2.67, 3.33, 4.00, 4.67, 5.33, 6.67, 8.00, 9.33, 10.00
		30.0	8-128	1.10, 1.50, 2.00, 3.00, 4.00, 5.00, 6.00, 7.00, 8.00, 10.00, 12.00, 14.00, 16.00
1" ³ , 1-1/4", 1-1/2"	381	3.5	1-14	3.0, 3.33, 4.00, 4.67, 5.33, 6.00, 6.67, 7.33, 8.00, 8.67, 9.33, 10.00, 10.67, 11.33, 12.00, 12.67, 13.33, 14.00, 14.67
		7.4	2-32	4.5, 5.0, 6.0, 7.0, 8.0, 9.0, 10.0, 11.0, 12.0, 13.0, 14.0, 15.0, 16.0, 17.0, 18.0, 19.0, 20.0, 21.0, 22.0
		13.4	4-57	6.00, 6.67, 8.00, 9.33, 10.67, 12.00, 13.33, 14.67, 16.00, 17.33, 18.67, 20.00, 21.33, 22.67, 24.00, 25.33, 26.67, 28.00, 29.33
		30.0	8-128	9.0, 10.0, 12.0, 14.0, 16.0, 18.0, 20.0, 22.0, 24.0, 26.0, 28.0, 30.0, 32.0, 34.0, 36.0, 38.0, 40.0, 42.0, 44.0

SIZE	MODEL NO.	HEAD LOSS IN FEET ²	PSID RANGE	GPM			HEAD LOSS IN FEET ²	PSID RANGE	HIGHER FLOW RATES/ NO INCREMENTS
				MIN.	INCREMENT	MAX			
1-1/2", 2", 2-1/2", 3"	3831	3.5	1-20	14.0	2.0	60	9.2	4-20	90, 110, 130
	3832	7.4	2-32	17.5	2.5	75	18.4	8-32	110, 135, 160
	3834	13.4	4-57	23.33	3.33	100	NONE		
	3838	30.0	8-128	35.0	5.0	150	NONE		

NOTES

¹ The optional strainer is internal and does not affect the dimensions. Strainer is available only on 1/2" to 1-1/2" models.
² Head Loss in Feet is provided for pump head calculations. (1 PSI = 2.307 Feet of Water)
³ 1" valve with 1-1/2" cartridge

Replaces form F-2852L and F-4356B

This specification © 2005 Griswold Controls

DIMENSIONS & WEIGHTS (NOMINAL)

SIZE	MODEL NO.	A	B	C	WEIGHT (LBS.)
1/2" SS	3K02B_	2.6	2.2	2.9	0.6
1/2"	380_	3.5	2.4	2.9	2
3/4"		3.8	2.5	3.0	2
1"		4.1	2.6	3.4	2
1" ³	381_	5.9	3.4	3.7	3
1-1/4"		6.1	3.5	4.2	3
1-1/2"		6.1	3.5	4.2	3
SIZE	MODEL NO.	D	E	F	WEIGHT (LBS.)
1-1/2"	383_	9.1	2.7	8.5	9.5
2"		8.9	2.7	8.5	9.5
2-1/2"		9.8	2.7	8.5	9.5
3"		10.2	2.7	8.5	9.5

MODEL NUMBER SELECTION⁴

1/2" SS

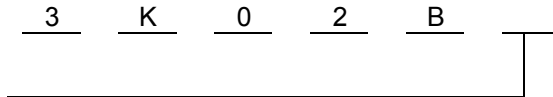

Add an "S" for Sweat, leave blank for FNPT

1/2" to 3"

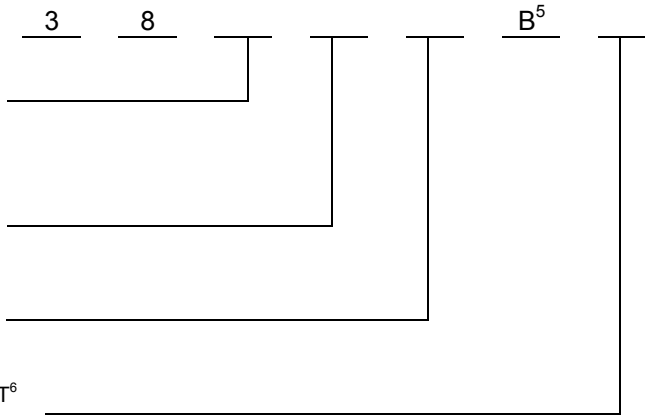

Insert 0 for 1/2", 3/4", and 1"

Insert 1 for 1", 1-1/4", and 1-1/2"

Insert 3 for 1-1/2", 2", 2-1/2", and 3"

Select a PSID control range

(1=1-14/1-20, 2=2-32, 4=4-57, 8=8-128)

Select a size (1/2"=E, 3/4"=F, 1"=H,

1-1/4"=J, 1-1/2"=K, 2"=L, 2-1/2"=M, 3"=N)

Add an "S" for sweat, leave blank for FNPT⁶

NOTES

⁴ Model no. and flow rate are indicated on label affixed to body.

⁵ For optional strainer, replace suffix "B" with "D". Strainer is available only on 1/2"-1-1/2" models.

⁶ Sweat is available only on 1/2" to 3/4" models.

Replaces form F-2852L and F-4356B

This specification © 2005 Griswold Controls