

Weld End Metering Station (2-1/2" - 18")

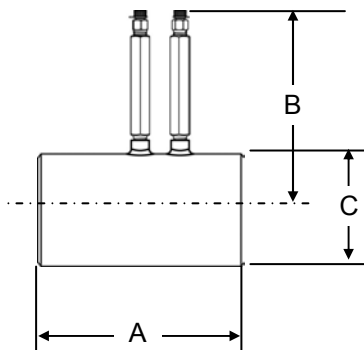

**SPECIFICATIONS:**

**PSI/Temperature Rating**

**Metering Station:**

**QuickSet:**

**Low Loss Venturi:**

**Body Material:**

**Butterfly Valve<sup>2</sup>:**

**End Connections:**

**Body Tappings:**

**Assembly:**

**Installation:**

400 PSI/250° F

175 PSI (14"-18": 150 PSI)<sup>1</sup>/250° F

Carbon Steel with Piezo-Ring to average low signal pickup.

Carbon Steel SA-53 Grade B.

Bronze disk, 400 series S.S. stem.

Beveled for welding

1/4" NPT with Brass P/T test valves

Valve comes fully assembled.

No straight-run is necessary for normal operation. Consult chart (F-4439) for exact Flow Constant and Permanent Pressure Drop calculations.

Weld End QuickSet with Handle Butterfly V (2-1/2"-6")

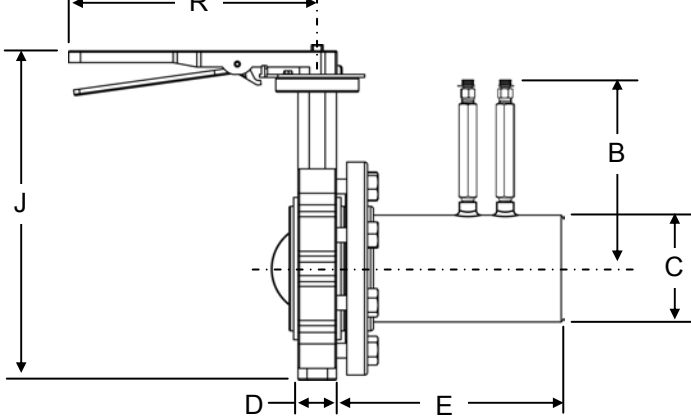

Gear/Hand Wheel Butterfly (8"-18")

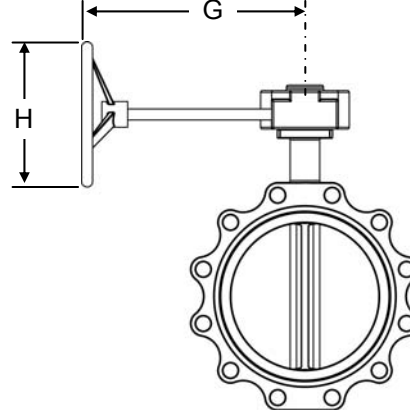

**FLOW RATES (+/-1%<sup>3</sup>)**

LINE SIZE	MODEL NO.	Cv Metering Station <sup>4</sup>	Cv Quickset <sup>4</sup>	GPM RANGE FOR 20"-100" W.C. ΔP (SET W/100" GAUGE)	GPM RANGE FOR 20"-300" W.C. ΔP (SET W/300" GAUGE)
2-1/2"	3QWM	171	135	39 - 87	39 - 151
3"	3QWN	269	201	66 - 147	66 - 255
4"	3QWP	580	417	116 - 260	116 - 451
5"	3QWQ	800	630	165 - 372	165 - 645
6"	3QWR	1250	980	272 - 624	272 - 1075
8"	3QWS	2100	1745	525 - 1180	525 - 2045
10"	3QWT	4000	3201	725 - 1610	725 - 2790
12"	3QWU	5700	4690	1249 - 2790	1249 - 4820
14"	3QWV	7300	6225	1548 - 3420	1548 - 5940
16"	3QWW	9600	8283	2490 - 5525	2490 - 9575
18"	3QWX	14500	12057	3305 - 7405	3305 - 12830

**NOTES**

<sup>1</sup> Higher PSI ratings are available. Contact factory.

<sup>2</sup> Butterfly Valve is standard on QuickSet only.

<sup>3</sup> Accuracy is based on Griswold's manufacturing tolerances. Accuracy for determining flowrate will be affected by the accuracy of the meter used to set the valve.

<sup>4</sup> Cv's are used to calculate permanent pressure drop.  $PSID = (Flow/Cv)^2$ . Consult chart F-4439 for flow measurement.

Replaces form F-4406C

This specification © 2005 Griswold Controls

**DIMENSIONS & WEIGHTS FOR METERING STATION (NOMINAL)**

LINE SIZE	A	B	C	WEIGHT (LBS.)
2-1/2"	5.8	7.3	2.9	3.1
3"	6.3	7.6	3.5	4.4
4"	7.9	8.0	4.5	8.0
5"	9.8	8.6	5.6	13.4
6"	10.3	9.1	6.6	18.2
8"	12.3	10.1	8.6	32.7
10"	15.5	11.2	10.8	58.0
12"	16.3	12.2	12.8	79.7
14"	16.5	12.8	14.0	95.1
16"	17.5	13.8	16.0	111.7
18"	16.8	14.8	18.0	121.0

**DIMENSIONS & WEIGHTS FOR QUICKSET (NOMINAL)**

LINE SIZE	B	C	D	E	G	H	J	R HANDLE	WEIGHT (LBS.)	
									W/ HANDLE	W/GEAR WHEEL
2-1/2"	7.3	2.9	1.8	6.0	N/A	N/A	11.6	10.5	17.5	N/A
3"	7.6	3.5	1.8	6.5	N/A	N/A	12.1	10.5	20.7	N/A
4"	8.0	4.5	2.0	8.1	N/A	N/A	13.6	10.5	31.3	N/A
5"	8.6	5.6	2.1	10.0	N/A	N/A	14.6	10.5	40.7	N/A
6"	9.1	6.6	2.3	11.5	N/A	N/A	15.6	10.5	53.6	N/A
8"	10.1	8.6	2.4	15.0	9.5	12.0	18.9	N/A	N/A	99.6
10"	11.2	10.8	2.6	18.0	9.5	12.0	21.3	N/A	N/A	151.0
12"	12.2	12.8	3.0	21.5	9.5	12.0	24.6	N/A	N/A	224.9
14"	12.8	14.0	3.0	24.0	9.5	12.0	26.8	N/A	N/A	303.5
16"	13.8	16.0	4.0	27.5	15.0	16.0	30.0	N/A	N/A	392.3
18"	14.8	18.0	4.5	31.8	15.0	16.0	31.6	N/A	N/A	511.5

**MODEL NUMBER SELECTION<sup>5</sup>**

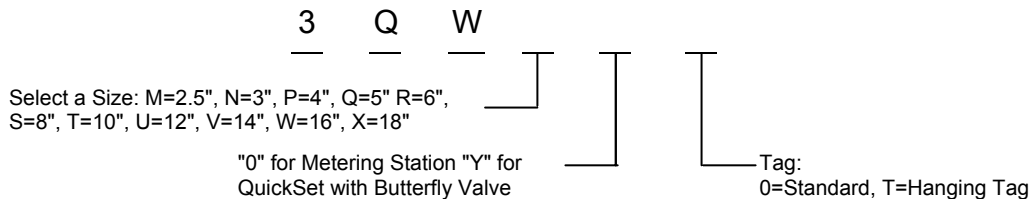

**NOTES**

<sup>5</sup> Model no. and flow rate are indicated on label affixed to body.  
Replaces form F-4406C

This specification © 2005 Griswold Controls

